

SAE Oval Flange

SAE Oval Flange is normally used to connect the different standard of hydraulic tubing and hose assemblies system, it has SAE 2 blot flange through hole as the same as SAE J518 required code 61 and 62 size: It is one kind of SAE Flange Clamps will be assembled with hydraulic hose assemblies, Metric or UNF thread port to hydraulic adapters then to metric and inch tubing assemblies.

SAE Flange Oval type is commonly used in industrial hydraulic system applications such as hydraulic excavator lower flange block distributor, screw compressor flange for hose assemblies. hydraulic motor and pump outlet oil flange port etc.

SAE Flange Oval with two through hole for SAE 6000PSI

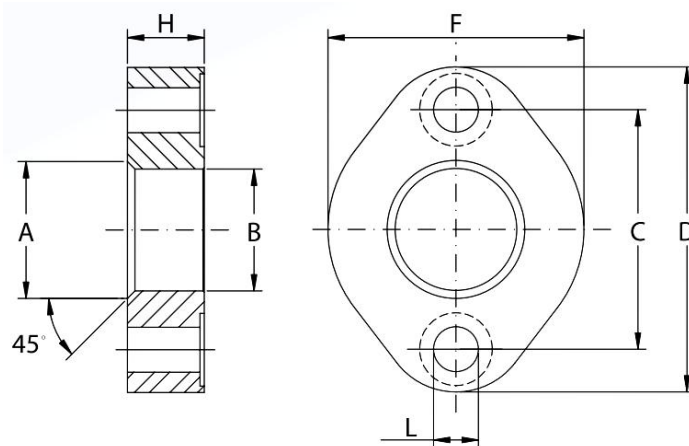

Max. operation pressure	Flange size	A	B	C	D	F	H	L
bar	in	mm	mm	mm	mm	mm	mm	mm
414	1.1/4"	49	44	73.9	103	78	25	14.5
414	1/2"	22	20.5	44.4	60	48	14	8.5
414	1/2"	27	24	44.4	60	48	14	8.5